



Future Technology Devices International Ltd.

UB232R

USB Mini-B FT232R Evaluation Module

Datasheet

Document Reference No.: FT_000055

Version 1.00

Issue Date: 2008-07-16

Future Technology Devices International Ltd (FTDI)

373 Scotland Street, Glasgow G5 8QB United Kingdom

Tel.: +44 (0) 141 429 2777 Fax: + 44 (0) 141 429 2758

E-Mail (Support): support1@ftdichip.com Web: <http://www.ftdichip.com>

Neither the whole nor any part of the information contained in, or the product described in this manual, may be adapted or reproduced in any material or electronic form without the prior written consent of the copyright holder. This product and its documentation are supplied on an as-is basis and no warranty as to their suitability for any particular purpose is either made or implied. Future Technology Devices International Ltd will not accept any claim for damages howsoever arising as a result of use or failure of this product. Your statutory rights are not affected. This product or any variant of it is not intended for use in any medical appliance, device or system in which the failure of the product might reasonably be expected to result in personal injury. This document provides preliminary information that may be subject to change without notice. No freedom to use patents or other intellectual property rights is implied by the publication of this document. Future Technology Devices International Ltd, 373 Scotland Street, Glasgow G5 8QB United Kingdom. Scotland Registered Number: SC136640

1 Introduction

The UB232R is the smallest USB - serial development module in the FTDI product range. To minimise the size of the module, the UB232R uses a standard USB mini-B connector. It is ideal for new development purposes as well as a platform for adding a USB interface to existing product designs.

The UB232R is based on the FTDI FT232RQ USB to Serial UART IC which handles all the USB signalling and protocols. The FT232R datasheet, **DS_FT232R**, is available at <http://www.ftdichip.com>,

The UB232R supports RTS/CTS hardware handshaking and is USB powered. The module supports data transfer rates from 300 baud to 3 Mbaud (RS422, RS485, RS232 and at TTL levels). In addition, two of the configurable CBUS pins of the FT232R are made available on the UB232R connector, allowing the UB232R to provide clock signals to external logic or they can be used to drive signal traffic indicator LEDs.

The UB232R is supplied with two 1x4 turned pin board headers with a standard 0.1" pitch. This aids rapid prototyping and development

The UB232R requires USB drivers, available free from <http://www.ftdichip.com>, which are used to make the FT232R on the UB232R appear as a virtual COM port (VCP). This then allows the user to communicate with the USB interface via a standard PC serial emulation port (TTY). Another FTDI USB driver, the D2XX driver, can also be used with application software to directly access the FT232R on the UB232R through a DLL. This is illustrated in the Figure 1.1

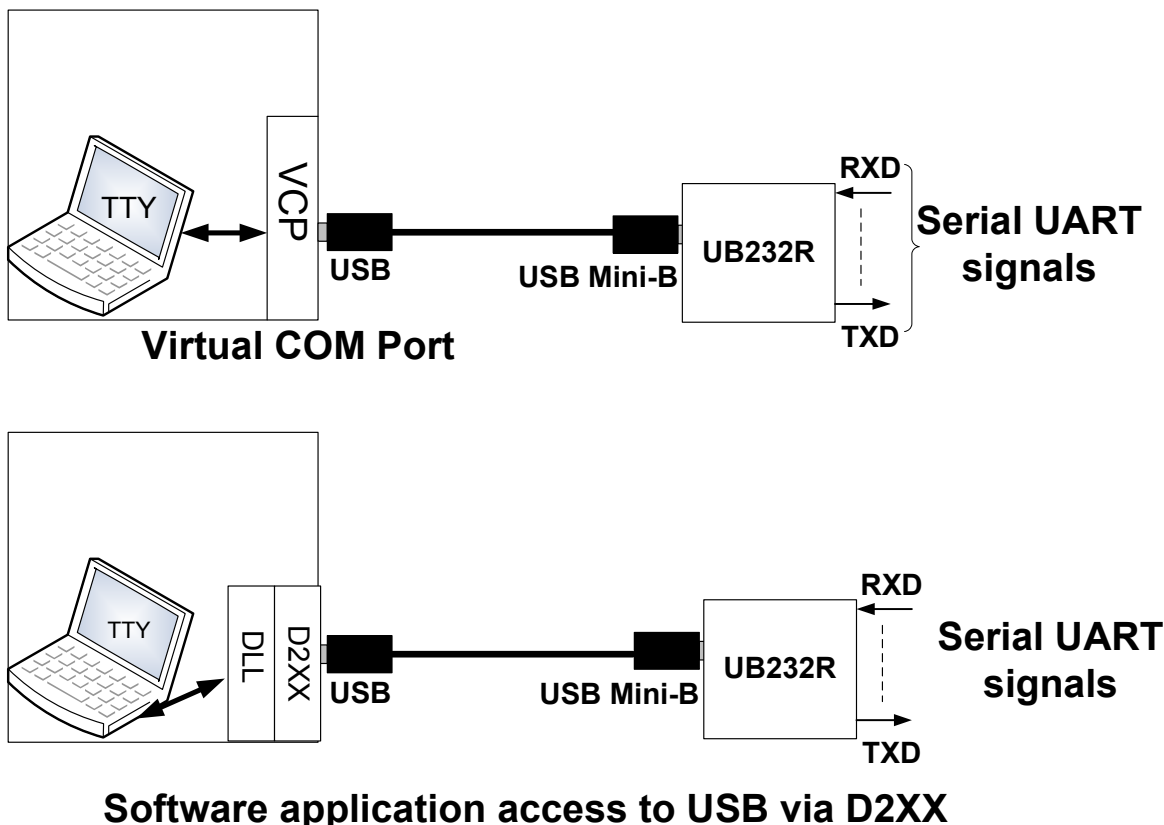

Figure 1.1 Using the UB232R

Drivers for the UB232R are available free from <http://www.ftdichip.com>.

Table of Contents

1	Introduction.....	1
2	Typical Applications.....	3
2.1	Driver Support	3
2.2	Features	3
3	Electrical Details.....	4
4	Mechanical details.....	5
5	Schematic Diagram	6
6	Contact Information.....	7
	Appendix A - FT232R EEPROM Configuration	8
	Appendix B - Revision History	9

2 Typical Applications

- Rapid USB integration into existing electronic systems.
- Prototyping platform for USB interface on new systems.
- USB Instrumentation integration.
- PCB real estate sensitive designs integrating smallest FTDI USB module available.

2.1 Driver Support

Royalty free VIRTUAL COM PORT

(VCP) DRIVERS for...

- Windows 98, 98SE, ME, 2000, Server 2003, XP and Server 2008
- Windows XP and XP 64-bit
- Windows Vista and Vista 64-bit
- Windows XP Embedded
- Windows CE 4.2, 5.0 and 6.0
- Mac OS 8/9, OS-X
- Linux 2.4 and greater

Royalty free D2XX Direct Drivers

(USB Drivers + DLL S/W Interface)

- Windows 98, 98SE, ME, 2000, Server 2003, XP and Server 2008
- Windows XP and XP 64-bit
- Windows Vista and Vista 64-bit
- Windows XP Embedded
- Windows CE 4.2, 5.0 and 6.0
- Linux 2.4 and greater

The drivers listed above are all available to download for free from **www.ftdichip.com**. Various 3rd Party Drivers are also available for various other operating systems - see **www.ftdichip.com** for details.

2.2 Features

The UB232R has the following feature:

- Reduced development time.
- Rapid integration into existing systems.
- USB powered – no external power supply needed.
- Based on FT232RQ device.
- Entire USB protocol handled by USB module.
- Small USB Type B connector to minimise PCB real estate usage.
- Data transfer rates from 300 baud to 3 Mbaud at TTL levels
- Lower Operating (15mA) and USB suspend mode current (70µA).
- Supports FT232R FTDIChip-ID™ with a unique USB serial number.
- Support for USB suspend and resume.
- UHCI / OHCI / EHCI host controller compatible.
- USB 2.0 Full Speed compatible.
- -40°C to +85°C operating temperature range.

3 Electrical Details

The electrical details and connections to the UB232R module are shown in Figure 3.1, Table 3.1 and Table 3.2.

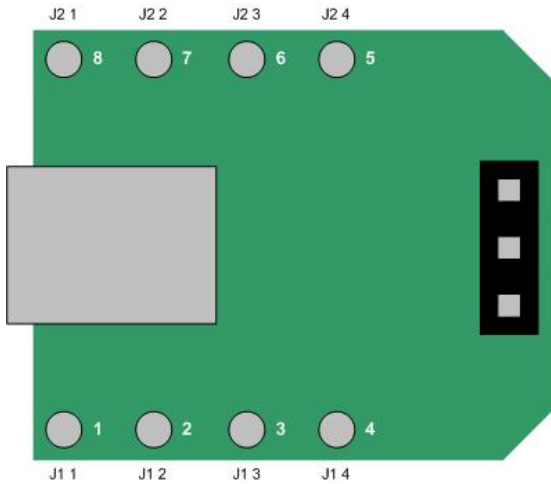

Figure 3.1 UB232R Electrical Connections (Top View)

Silkscreen Pin	Connector Pin	Name	Description
1	J1-1	GND	OV Power pin
2	J1-2	VCC	+5V Power from USB Interface
3	J1-3	RTS#	FT232R RTS pin
4	J1-4	CTS#	FT232R CTS pin
5	J2-4	CBUS1	FT232R CBUS1 pin
6	J2-3	CBUS0	FT232R CBUS0 pin
7	J2-2	RXD	FT232R RXD pin
8	J2-1	TXD	FT232R TXD pin

Table 3.1 UB232R Module Connection

The signal output level on connectors J1 and J2 are controlled by the voltage supplied to the VCCIO pin 4 on the FT232R. The VCCIO is selected between the +5V (VCC from USB) or the output of the FT232R Low Drop Out (LDO) +3.3V regulator. The VCCIO selection is done by fitting a link on connector J3. The selection is shown in Table 3.2.

Connector J3	Function
Link 1-2 connected	VCCIO and RESET# driven connected to VCC (+5V)
Link 2-3 connected	VCCIO and RESET# driven connected to +3.3V output of FT232R LDO regulator

Table 3.2 UB232R Module VCCIO selection

4 Mechanical details

The mechanical details of the UB232R are shown in Figure 4.1:

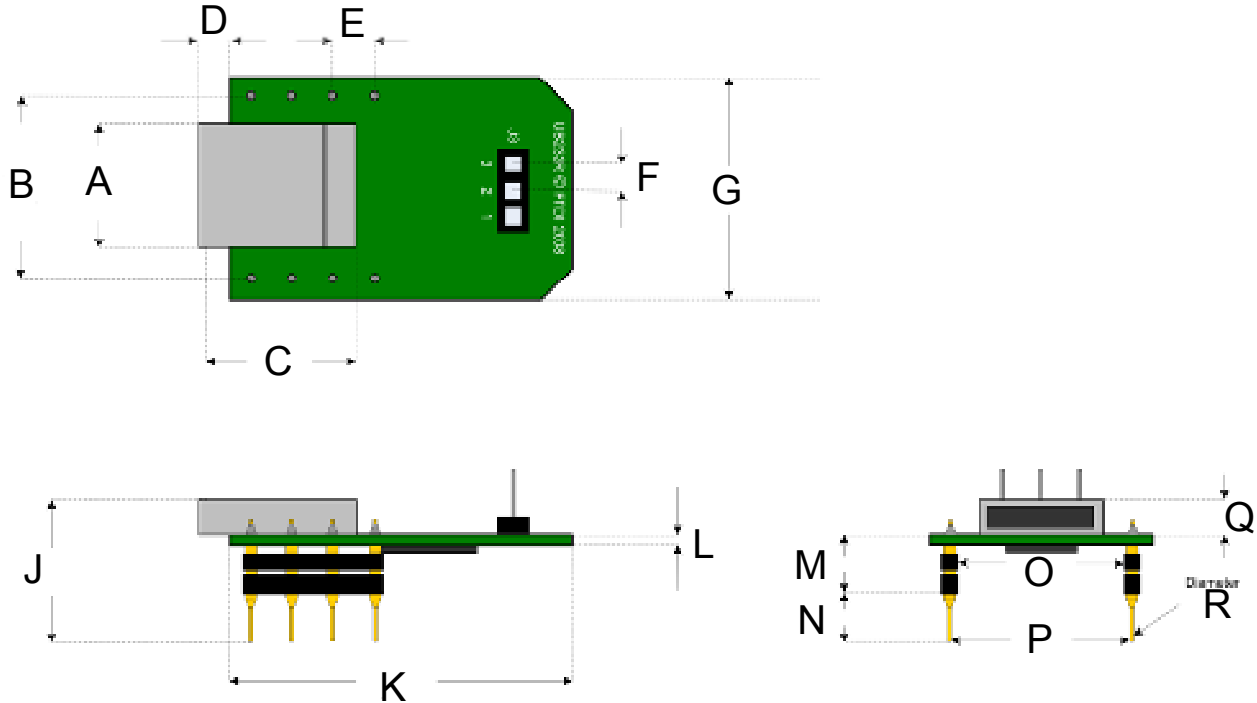

	Dimensions (mm)		Dimensions (mm)		Dimensions (mm)		Dimensions (mm)
A	7.0 +/- 0.1	F	2.54 +/- 0.005	M	8.0 +/- 0.1	R	0.5 +/- 0.005
B	12.0 +/- 0.1	G	15.00 +/- 0.2	N	5.0 +/- 0.1		
C	7.0 +/- 0.1	J	17.0 +/- 0.2	O	10.0 +/- 0.1		
D	2.0 +/- 0.005	K	18.0 +/- 0.2	P	13.0 +/- 0.1		
E	2.54 +/- 0.005	L	1.60 +/- 0.005	Q	4.0 +/- 0.1		

Figure 4.1 UB232R Module Dimensions

5 Schematic Diagram

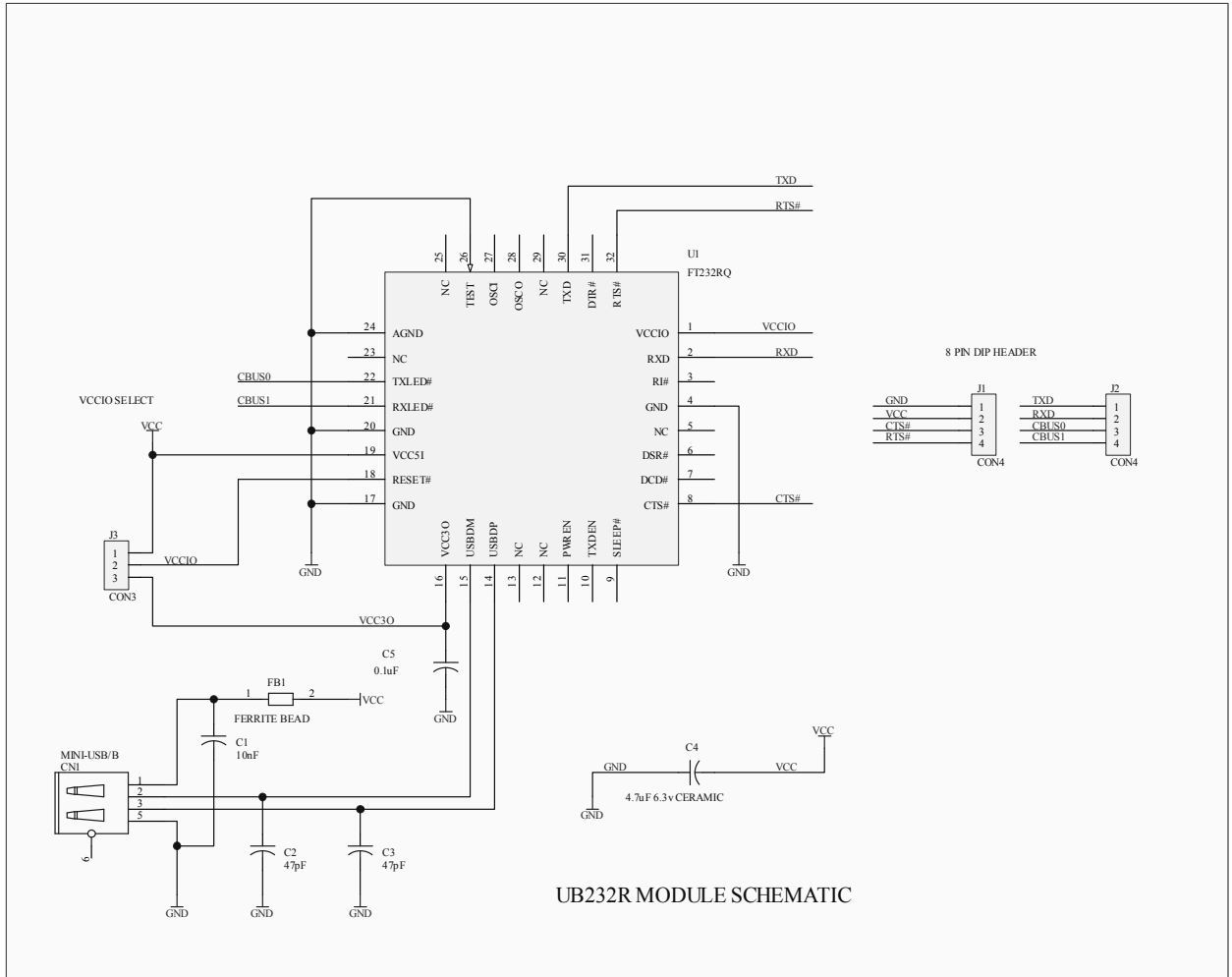

Figure 5.1 UB232R Module Schematic

6 Contact Information

Head Office – Glasgow, UK

Future Technology Devices International Limited
373 Scotland Street
Glasgow G5 8QB
United Kingdom
Tel: +44 (0) 141 429 2777
Fax: +44 (0) 141 429 2758

E-mail (Sales) sales1@ftdichip.com
E-mail (Support) support1@ftdichip.com
E-mail (General Enquiries) admin1@ftdichip.com
Web Site URL <http://www.ftdichip.com>
Web Shop URL <http://www.ftdichip.com>

Branch Office – Taipei, Taiwan

Future Technology Devices International Limited (Taiwan)
4F, No 18-3, Sec. 6 Mincyuan East Road
Neihu District
Taipei 114
Taiwan, R.O.C.
Tel: +886 (0) 2 8791 3570
Fax: +886 (0) 2 8791 3576

E-mail (Sales) tw.sales1@ftdichip.com
E-mail (Support) tw.support1@ftdichip.com
E-mail (General Enquiries) tw.admin1@ftdichip.com
Web Site URL <http://www.ftdichip.com>

Branch Office – Hillsboro, Oregon, USA

Future Technology Devices International Limited (USA)
7235 NW Evergreen Parkway, Suite 600
Hillsboro, OR 97123-5803
USA
Tel: +1 (503) 547 0988
Fax: +1 (503) 547 0987

E-Mail (Sales) us.sales@ftdichip.com
E-Mail (Support) us.admin@ftdichip.com
Web Site URL <http://www.ftdichip.com>

Distributor and Sales Representatives

Please visit the Sales Network page of the FTDI Web site for the contact details of our distributor(s) and sales representative(s) in your country.

Appendix A - FT232R EEPROM Configuration

This FT232R device within the UB232R module contains an EEPROM which contains the USB configuration descriptors for that device. When the UB232R is plugged into a PC or a USB reset is performed, the PC will read these descriptors. The default values stored into the internal EEPROM are defined in Table 6.1

Parameter	Value	Notes
USB Vendor ID (VID)	0403h	FTDI default VID (hex)
USB Product UD (PID)	6001h	FTDI default PID (hex)
Serial Number Enabled?	Yes	
Serial Number	See Note	A unique serial number is generated and programmed into the EEPROM during device final test.
Pull down I/O Pins in USB Suspend	Disabled	Enabling this option will make the device pull down on the UART interface lines when the power is shut off (PWREN# is high).
Manufacturer Name	FTDI	
Product Description	UB232R	
Max Bus Power Current	90mA	
Power Source	Bus Powered	
Device Type	FT232R	
USB Version	0200	Returns USB 2.0 device description to the host. Note: The device is be a USB 2.0 Full Speed device (12Mb/s) as opposed to a USB 2.0 High Speed device (480Mb/s).
Remote Wake Up	Enabled	Taking RI# low will wake up the USB host controller from suspend.
High Current I/Os	Enabled	Enables the high drive level on the UART and CBUS I/O pins.
Load VCP Driver	Disabled	Makes the device load the VCP driver interface for the device.
Invert TXD	Disabled	Signal on this pin becomes TXD# if enable.
Invert RXD	Disabled	Signal on this pin becomes RXD# if enable.
Invert RTS#	Disabled	Signal on this pin becomes RTS if enable.
Invert CTS#	Disabled	Signal on this pin becomes CTS if enable.

Table 6.1 Default Internal EEPROM Configuration

The internal EEPROM in the FT232R can be re-programmed over USB using the utility program MPROG. MPROG can be downloaded from the www.ftdichip.com. Version 2.8a or later is required for the FT232R chip. Users who do not have their own USB Vendor ID but who would like to use a unique Product ID in their design can apply to FTDI for a free block of unique PIDs. Contact FTDI support for this service.



Appendix B - Revision History

Version 1.00 Full datasheet released

July 2008